

Prototyping of EMG-Controlled Prosthetic Hand with Sensory System [★]

Ivan I. Borisov* Olga V. Borisova* Sergei V. Krivosheev*
Roman V. Oleyunik* Stanislav S. Reznikov*

* *Department of Mechatronics, ITMO University, Kronverkskiy pr.,
49, St. Petersburg, 197101, Russia*

Email: borisow.i.i@yandex.ru

Abstract: This paper presents a highly integrated underactuated prosthetic hand equipped with feedback system for performing man-machine interference. The prosthetic hand is composed of five fingers. The hand is actuated by six DC motors, one for each finger plus one for thumb opposition. Motors are inside the palm, while sensors spread all over the construction. The integrated control system is consist of motion control subsystem and sensory subsystem. The motion control subsystem is crucial as the sensory subsystem for both the amputee using prosthetic hand and its control algorithms. Thanks to numerous sensors it is possible to achieve better controlability of phalanges and, especially, the fingertip. For getting the knowledge of grasping force of the prosthetic hand a sensory feedback system between amputee and device is proposed. Force sensor transmits the data about force of grasp to controller, potentiometers and hall effect sensors transmit information about phalanx position and joint angles, while controller convert these signals into vibration intensity of vibromotors, sound signals given by the piezospeaker about hand state. In addition, visual information helps amputee to control the prosthetic hand. Vibromotors located on the surface of amputee arm in special wristband. Thus data input consisting of 3 independent channels of information, makes the control of the hand much easier. Thanks to vibration signals the amputee is able to feel how strong he hold a object. At the end of this paper, the control system is described.

Keywords: Prototyping, Bio control, Control applications, Electronic applications, Sensor systems.

1. INTRODUCTION

A lot of robotic hands have been developed by research groups all over the world in recent years. The prosthetic hand technology has made great progress thanks to biotechnology and robotics. Some devices, such as Ottobock Hand, I-Limb Hand, Bebionic Hand have become available on the market. But commercial prostheses usually have simple structure and rarely no sensory system. Due to the lacks of commercial devices, great number of state-of-the-art robotic hands or grippers with more degree of freedoms (DOFs) and sensors have been developed, such as CyberHand (Carrozza et al. (2006)), HIT hand (Liu et al. (2014)), GCUA Hand (Che and Zhang (2010)), Smarthead (Cipriani et al. (2009)).

Process of bidirectional transmission of information from a human brain to the hand cannot be fully implemented between amputee and the prosthetic hand. To solve this problem, a lot of scientific teams have created some alternative approaches. Currently most of prosthetic hands can be controlled by means of electromyography surface electrodes (EMG) (Lake and Miguelez (2003)). EMG technology allows to detect electrical activity within muscles of the patients arm, thereby the amputees could grasp and

operate everyday objects via prosthetic hand by processing EMG signals from residual muscles and visual information channel.

Dexterous hands can perform almost all movements of a real hand, and even give some gestures which humans feel hard to pose. The prosthetic hand is getting close to the real human hand. But so far, none of the current prosthetic hands is able to restore the acceptable perception for upper-limb amputees. Drawback of reliable sensory feedback is the biggest defect of these prosthetics. Design of the sensory feedback is not still common, as a mature approach has not been created. There are three kinds of existing sensory feedback approaches: cutaneous mechanical stimulation (CMS), transcutaneous electrical nerve stimulation (TENS) and direct peripheral nerve electrical stimulation (DPNES) Chai et al. (2014). There is no universally-recognized and perfect approach to realize the perceptual embodiment of a prosthetic hand. CMS is non-invasive feedback approaches, as well as TENS, while DPNES is invasive. Each of them had advantages and disadvantages describe in Chai et al. (2014); Antfolk et al. (2013).

In this paper a prosthetic hand system is proposed to obtain the sensory feedback via vibrotactile stimulation, which evoked by a mechanical vibration of the skin,

* This work was supported by the Government of the Russian Federation, Grant 074-U01.

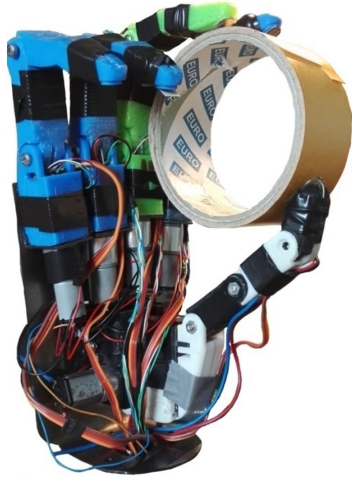

Fig. 1. Prototype of the prosthetic hand

and sound information from piezospeaker. This prosthetic hand based on underactuated mechanisms has 6 DOF and 11 rotating joints. The interaction between a human and the prosthetic hand is based on discrimination of EMG signals and execution of a feedback system. The work described in this paper is an example of design of elements necessary to build an electromechanical hand: the mechanism, sensory system and control system.

This paper is organized as follows. Section 2 describes the mechatronic resources including the mechanical design of the hand and description of the operation process. Section 3 proposes the feedback sensory system including sensory subsystems and sensory configuration. The control system is proposed in Section 4. Finally, the paper is wrapped up with Conclusion.

2. MECHATRONIC RESOURCES

2.1 Mechanical Design

The prosthetic hand is composed of five active fingers. The hand is actuated by six direct current (DC) motors, one for each finger plus one for thumb opposition. The opposability of the thumb is very important for dexterity and grasping ability. DC motors are very balanced in the efficiency, response time and reliability. The motors are mounted inside the palm, while the sensors are spread all over the construction. The device is just a little bigger than a real human hand, weighs about 450g. The prototype of the hand is shown in Fig. 1. Digits and other construction parts are made of ABS plastic on 3D printer, while spools are made of aluminum, hull is made of steel.

The underactuated system (UA) of the hand allows to flexing of the two finger joints with a single DC motor, but it does not allow to move independently each phalanges. Each finger is able to rotate around the metacarpophalangeal (MCP) and proximalinterphalangeal (PIP) joints for total of 11 movable joints of the entire hand (including thumb opposition). In an effort to decrease the cost of the device the distal interphalangeal (DIC) was decided to remove as unnecessary. Each finger configuration is determined by the shape of the object to grasp. Thus

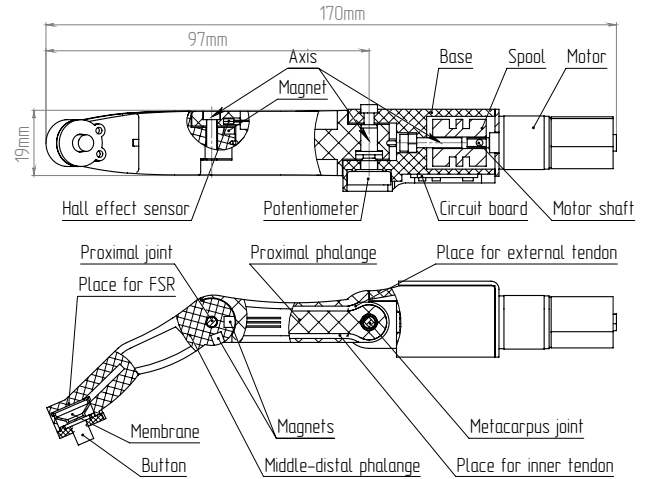

Fig. 2. Structure of 2-joint index finger

grasp of the hand becomes adaptive. This is achieved by advantage of underactuated linkage mechanism.

Underactuated function can drive many degrees of freedom of the artificial hand. Moreover, a number of motors may be less than DOF of the hand Che and Zhang (2010). Thus, this kind of design enhance the functionality of the device and mimics the motion of real human digit. The goal is to get stable grasp with different objects without increasing complexity of the mechanism and the control system. Hence the hand is able to grasp objects, but joints must bend in the fixed order. The developed robotic hand is based on the mechanism linkage and tendon transmission. The hand is able to grasp different objects with a shape adaptive function. In this case the middle-distal phalange rotates around the PIP joint until it is blocked by objects or stood in the final position and then proximal phalange starts to rotate until it is blocked by objects or stood in the final position as well. In this way, the finger can grasp objects self-adaptively. The traditional UA function makes the robotic hand less depended on sensors and control. However, to provide more dexterously and controlability sensitization is highly important.

The finger of the hand with 2 joints uses the tendon mechanism. The metacarpus joint is fixed in base (metacarpus), proximal joint is fixed in proximal phalange and distal joint is missing as unnecessary. The UA transmission is fixed in base. The proximal phalange is sleeved with the metacarpus joint; the middle-distal phalange is sleeved with proximal joint. An assembly method is shown in Fig. 2.

The UA transmission of each finger is custom-made driving pulley (or a spool). The spool is attached to the ordinary DC motor shaft. The two tendons (nylon ropes) per finger are used to provide movement. Both of these tendons connects the spool and fingertip but one of these located on inner side of the finger and other tendon on external side of the finger. The wrapping directions of the inner tendon is different from the external one. The inner tendon drives the finger to be flexed and external one drives the finger to be extended.

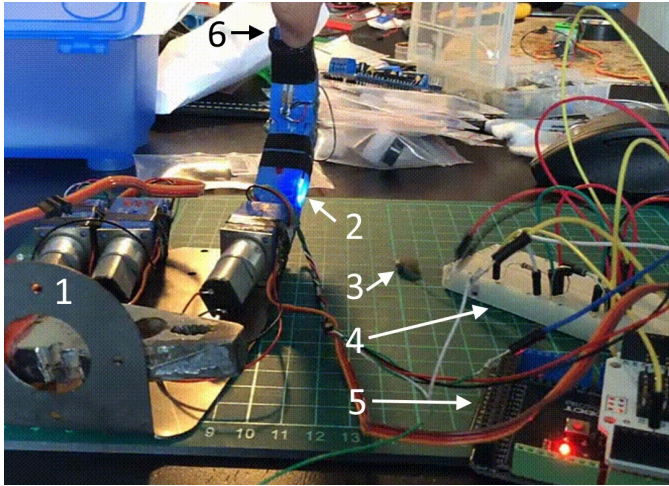

Fig. 3. Testing of the feedback system. Hull of the hand (1); LED (2); Vibromotor (3); Circuit board (4); Arduino (5); FRS (6)

2.2 Operation Process

Finger motion proceeds in several steps: (1) motor rotates forward, (2) spool winds inner tendon to move. Wrapping directions of the inner and external tendons are different. (3) Thus inner tendon becomes strained, while external tendon relaxes. The proximal and middle-distal phalanges will rotate around the metacarpus joint together as a rigid body until proximal phalange is blocked by the object or stands in the final position. After that only the middle-distal phalange rotates around the proximal joint until it is blocked by the object or stands in the final position. Thus the finger can grasp objects self-adaptively.

When the motor rotates back the spool unwinds these two tendons, so inner tendon relaxes, and external one becomes strained. The external tendon drives the finger to be extended

The phalanges have been printed on 3d printer using ABS plastic. The pulleys have been made of aluminum in order to provide light weight and durability to the construction. The body part have been made from sheet steel.

3. FEEDBACK SENSORY SYSTEM

All sensors which are described below are needed to provide sensory feedback and autonomous hand operation. Feedback is important feature for both amputees and developers. The electromechanical prosthetic hand is supposed automatically adapt to a shape of the object and to provide a firm grip without slippage. There is a quite difference between grasping a plastic and glass cups.

According to the classification of Sherrington Carrozza et al. (2006), the sensory system consists of two types of "artificial sensations" for maximum similarity with human feelings:

- the proprioceptive subsystem provides useful information about hand kinematics and movement;



Fig. 4. Feedback system architecture. (1) Audio information (piezospeaker signals and sound of gearboxes); (2) Visual information (LED signals and movement of fingers); (3) Vibration of vibromotors.

- the exteroceptive subsystem provides information about interaction between the grasped object and the hand, and between the object and the environment.

The motion control system of the prosthetic hand has to meet the requirements of light weight, small size, flexible mounting and low power consumption. Numerous sensors are integrated in the control system. The proprioceptive subsystem is based on Hall effect sensors and potentiometers embedded in the mechanism (see Fig. 2). The exteroceptive subsystem is based on a force resistor sensor (FRS) mounted on the fingertips.

Joints have maximum density of sensors. Each proximal joint is equipped with Hall effect sensor in order to track the state of middle-distal phalange. Each metacarpus joint is equipped with potentiometer mounted to the axis for tracking the orientation of proximal phalange. The control of the finger movement similar to servomotor control. Design of the hand allows precise control of angular position, velocity and acceleration of the finger movement due to the fact that potentiometer shaft attached to the proximal phalange in metacarpus joint. Position control of the middle-distal phalange can be obtained by means of the Hall effect sensor embedded in the proximal joint (see Fig. 2). The Hall effect sensors are devices which are activated by an external magnetic field. There are two magnets with different polarity located inside the middle-distal phalange. The Hall effect sensor is mounted to the proximal phalange. It is used for sensing position and direction of the movement; for detecting initial and final positions of the each phalange. The bipolar hall effect sensor was used in this application. Using both the potentiometer and Hall effect sensor is possible to achieve better controllability of the phalanges and, especially, fingertip.

As was mentioned above, exteroceptive subsystem is based on a on-off tactical force resistor sensors (FSR) per each fingertip. The developed algorithm has allowed to track the change in resistance value coming from the sensor, which indicates that the prosthetic touches object. Thus, prosthesis feedback can be created with the accuracy similar

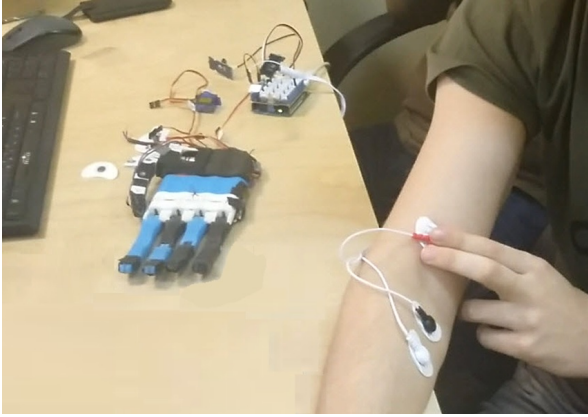

Fig. 5. Testing control system based on EMG signals

to the human perception. The sensors are connected to the Arduino Mega (see Fig. 3) board.

To measure the grasping force of the prosthetic hand a sensory feedback system between an amputee and the device is proposed. This feedback system is necessary for making amputees be able to control the grasp force. 3 vibration motors located on an amputee skin surface in special wristband. The force resistor sensor (FSR) located on the fingertip transmits data about grasp force to the Arduino controller. Precision grips produced by the fingertips. This is why FRS is located on the special place on the fingertip (see Fig. 2). Thus it is possible to detect grasps. Hence the hand is able to perform stable grasps. The latter converts these signals into vibration the intensity of vibration motors. Thus the amputee is able to feel how strong he holds an object. In addition, user hears piezospeaker signals and gearbox sounds and sees LED signals, and of course, the device (see Fig. 4). Thus data input consisting of 3 independent channels of information, makes the control of the hand much easier.

4. CONTROL SYSTEM

Different research groups use three main approaches of control strategies for artificial prosthetic hands. First one is based on using of electroencephalography, second one is based on different mechanical types of data acquisition. For example, the gyroscopes with accelerometers use stump orientation or acceleration in control tasks. And the last one is a control system for the hands movement actuation based on the surface electromyography (see Fig. 5). Myoelectric control systems based on pattern recognition have been proposed for the next generation of multi-functional upper-limbs prostheses Carrozza et al. (2006). During pattern-recognition control, the program identifies amputee movements by using pattern with few channels of surface electromyography signals. The program classifies the pattern and sends commands to the prosthetic hand.

In this paper the latter type was chosen. For the first trials “Grove - EMG Detector” was used. The electrodes were placed on the flexor carpi radialis according to the instructions. The signals from the sensor after muscle contraction were sent to the Arduino Mega (see Fig. 6). To prevent unexpected movements into the body of control code threshold was added. After obtaining of the desired value the control system sends the signals to the motors

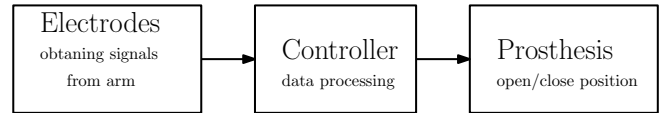

Fig. 6. Scheme of the prosthesis control system

to move into the specified position (desirable grasp). If the user want to return into the initial position amputee just need to make another muscle contraction.

In this version the hand is able move into one position, but in the nearest future it will be available to use at least three different type of the grasps via using just one electrode. This approach was described in Krivosheev and Ormanov (2014), but these signals must be processed in a special application or program. It will be done in the further work.

5. TESTING

To verify the effectiveness of the proposed version of the control and feedback systems, a study involving five healthy people was conducted. The developed prosthetic hand was located on a rigidly fixed bracket. There was a bottle of water, which it was planned to grip by the hand. At the first stage the feedback sensors were not fed to the active arm of the participants, thus they could only visually evaluate the effectiveness of the prosthetic. At the second stage, LEDs and piezospeaker informing about touching the surface were turned on, in addition, vibromotors were placed on the user’s arm. Comparing the sensations from the gripping of the object between the first and second stage, the participants of the experiment noted that in the second stage they fully perceived the information due to the light signals, sound signals and tactile indication. For an objective assessment of the received information, it will be necessary to conduct additional studies using special equipment.

6. CONCLUSION

The concept of novel anthropomorphic prosthetic hand are presented. In this paper improvements in the mechanical part of the developed prosthetic hand and first trials of the control system and feedback were described. This paper presents the highly integrated underactuated prosthetic hand equipped with the feedback system for performing man-machine interface. The prosthetic hand is composed of five fingers. The hand is actuated by six DC motors, one for each finger plus one for thumb opposition. The motors are placed inside the palm, while the sensors are spread all over the construction.

The proposed improvements in the mechanics increased dexterity and controllability. The integrated control system is consist of motion control subsystem and sensory subsystem. The motion control subsystem is crucial as the sensory subsystem for both the amputee using prosthetic hand and its control algorithms. Thanks to numerous sensors it is possible to achieve better controllability of the phalanges and, especially, fingertip. For getting the knowledge of grasping force of the prosthetic hand a sensory feedback system between amputee and device is proposed. Force sensor transmits the data about force of grasp to

controller, potentiometers and hall effect sensors transmit information about phalanx position and joint angles, while controller convert these signals into vibration intensity of vibromotors, sound signals given by the piezospeaker about hand state. In addition, visual information helps amputee to control the prosthetic hand. Vibromotors located on the surface of amputee arm in special wristband. Thus data input consisting of 3 independent channels of information, makes the control of the hand much easier. Thanks to vibration signals the amputee is able to feel how strong he hold a object.

The prosthetic hand can be applied in two aspects. Firstly, it can be used as prosthesis. Secondly, it can be utilized as gripper of multi-DOF robot arm. But it needed to decrease weight and size of the hand and make its construction more robust and simple-to-assemble. The complex of implemented sensors gives an opportunity to simplify control of the hand.

REFERENCES

- Antfolk, C., DAlonzo, M., Rosén, B., Lundborg, G., Sebelius, F., and Cipriani, C. (2013). Sensory feedback in upper limb prosthetics. *Expert review of medical devices*, 10(1), 45–54.
- Carrozza, M.C., Cappiello, G., Micera, S., Edin, B.B., Beccai, L., and Cipriani, C. (2006). Design of a cybernetic hand for perception and action. *Biological cybernetics*, 95(6), 629–644.
- Chai, G.h., Sui, X.h., Li, P., Liu, X.x., and Lan, N. (2014). Review on tactile sensory feedback of prosthetic hands for the upper-limb amputees by sensory afferent stimulation. *Journal of Shanghai Jiaotong University (Science)*, 19, 587–591.
- Che, D. and Zhang, W. (2010). Dexterous and self-adaptive under-actuated humanoid robot hand: Gcua hand ii. In *International Conference on Intelligent Robotics and Applications*, 47–58. Springer.
- Cipriani, C., Controzzi, M., and Carrozza, M.C. (2009). Progress towards the development of the smarthead transradial prosthesis. In *2009 IEEE International Conference on Rehabilitation Robotics*, 682–687. IEEE.
- Krivosheev, S. and Ormanov, D. (2014). Control of the multi-link manipulator model by means of current value removed from hand surface. *Automation. Modern technologies*, 2, 41–45.
- Lake, C. and Miguelez, J.M. (2003). Evolution of microprocessor based control systems in upper extremity prosthetics. *Technology and Disability*, 15(2), 63–71.
- Liu, Y.w., Feng, F., and Gao, Y.f. (2014). Hit prosthetic hand based on tendon-driven mechanism. *Journal of Central South University*, 21, 1778–1791.